

[Type text]

[Type text]

Special feet details

How it work's

Beta can make engine feet to suit your existing engine beds. Once you receive this form please fill out the measurements you need changing and return to Beta. Beta will create a general arrangement drawing showing the measurements your required and additional measurements that may be useful (e.g. height of engine from your bearers). See to picture shown below. Once you receive this then please check and sign. If you find a problem then change the measurement's or contact Beta and we will revise the drawing until it is correct.

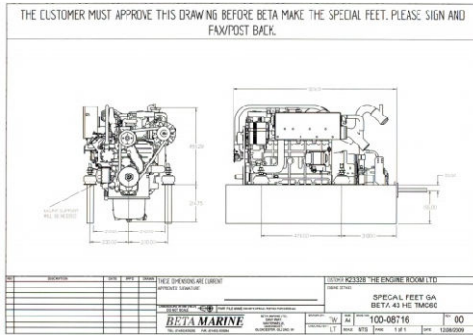
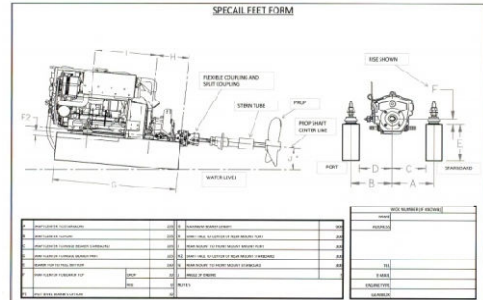

Once we receive the signed drawing Beta will manufacture the engine feet and were possible fit them to the engine. If they will not fit in the shipping skid we will send the feet loose and fit standard feet. All bolts will be provided to fit the feet to the engine. You will need to drill and tap new holes for the flexible mounts unless you have the same bolt holes as the mount drawings below (please note the engine size).

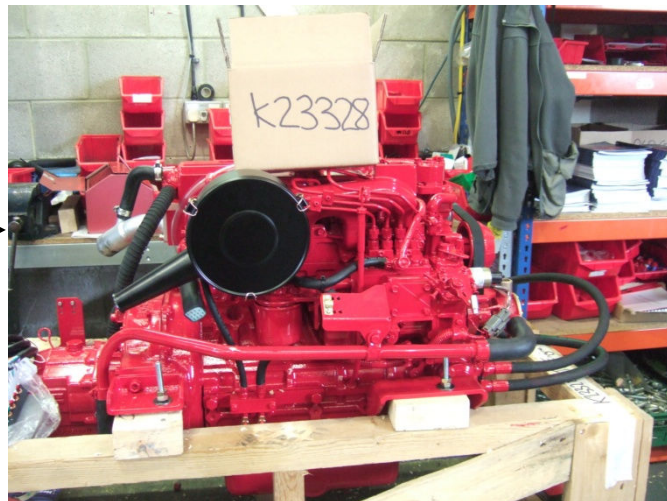

Measuring your engine beds

There are many ways to measure and fill in the attached form. Here are some helpful tips and information to help you take good measurements. As you can appreciate the measurements you provide in this form is used in our 3d CAD system and can only be accurate if the information provided is correct. The flexible mounts are adjustable in height, port and starboard for exacted alignment with the prop on installation. The distances differ depending on size of engine so please see flexible mount details below.

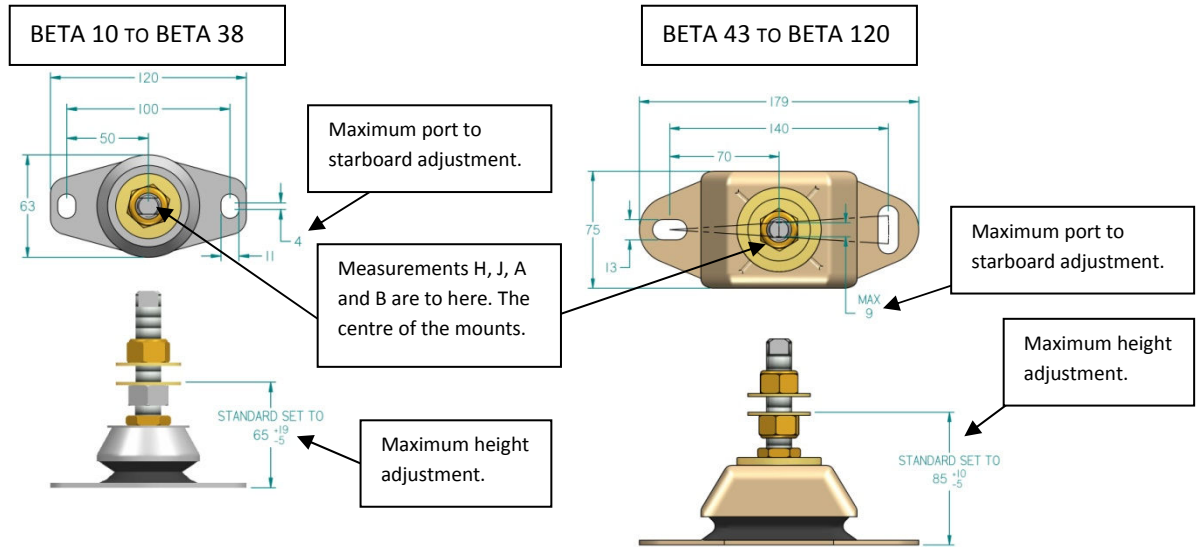

- When filling out the form if the only difference between our standard engine and yours is height or width then just fill out the appropriate box's leaving the other blank.

- As you can see from the sketch all the measurements are from the prop shaft (the datum) as this is the most important area to align and cannot be moved.

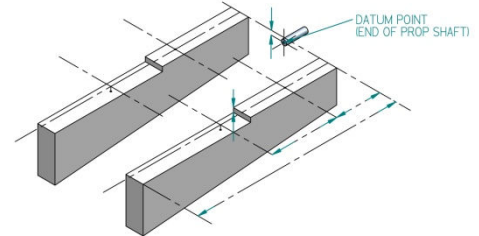

- When measuring dimension F. It is advisable to measure the bearers a little low, as you can always add a spacer plate to raise the mounts. If you measure the bearers a little height you wouldn't want to cut the engine beds to lower the mount. As you can see above Beta set the mount at a height so you can lower the engine by 5mm from dimension F. This is to help final installation when aligning the prop shaft.

- If your bearers are stepped (e.g. the rear bearers are higher than the front) Then just measure the difference between them and add it the dimension F2. If the bearers are higher at the front please type/write – before the dimension (this is very uncommon).

- When the engine is installed at an angle (dimension J) Please note the maximum angle is 15° but this is not recommended, and you should always try and keep the engine level were possible (by using a down angle gearbox for example). Otherwise you will need to take careful attention to oil levels, quantity and water filling (expansion bottle). Please speak to Beta for help.

- If your prop shaft is not parallel to you bearers you will need to provide Beta with more information. Please contact Beta for assistance.

- Please make a note of any problem areas that you may think Beta should know about (e.g. head room or sump restrictions).

- Were the flexible mounts are bigger than your bearers Beta can provide pads witch fit between the flexible mount and your bearers. Please see sketch.

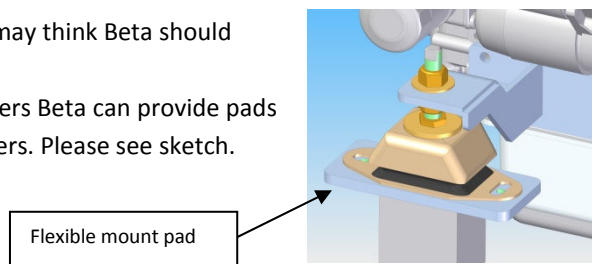

**SPECIAL FEET FORM
HEAT EXCHANGER**

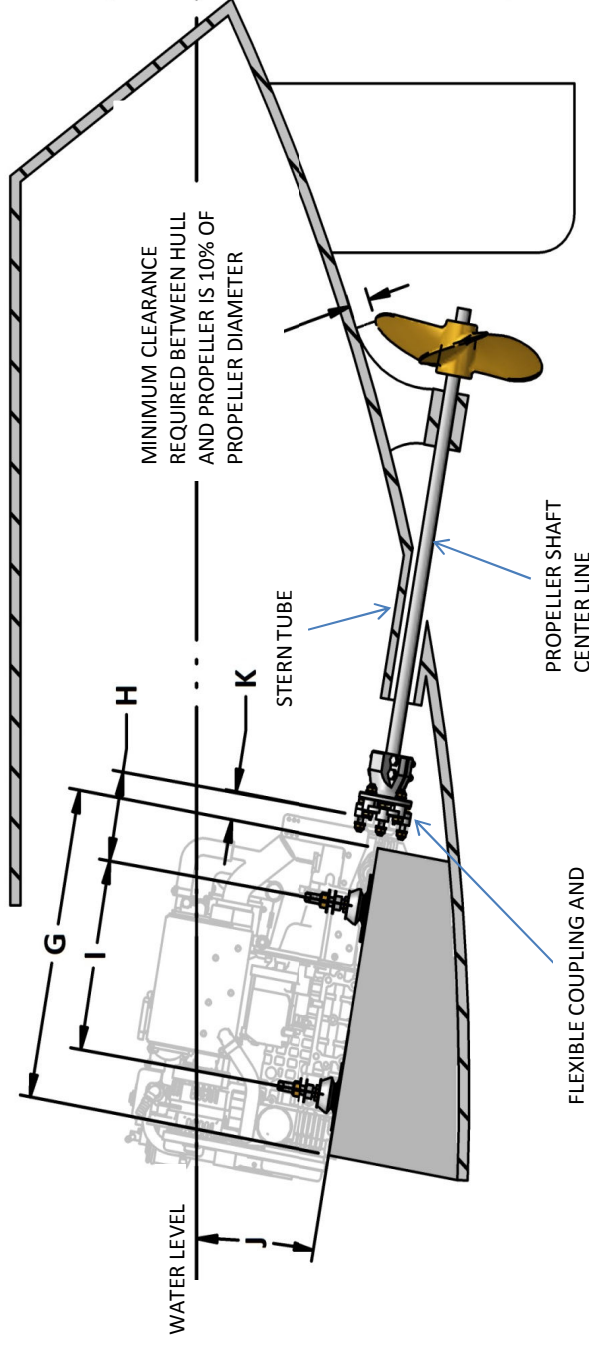
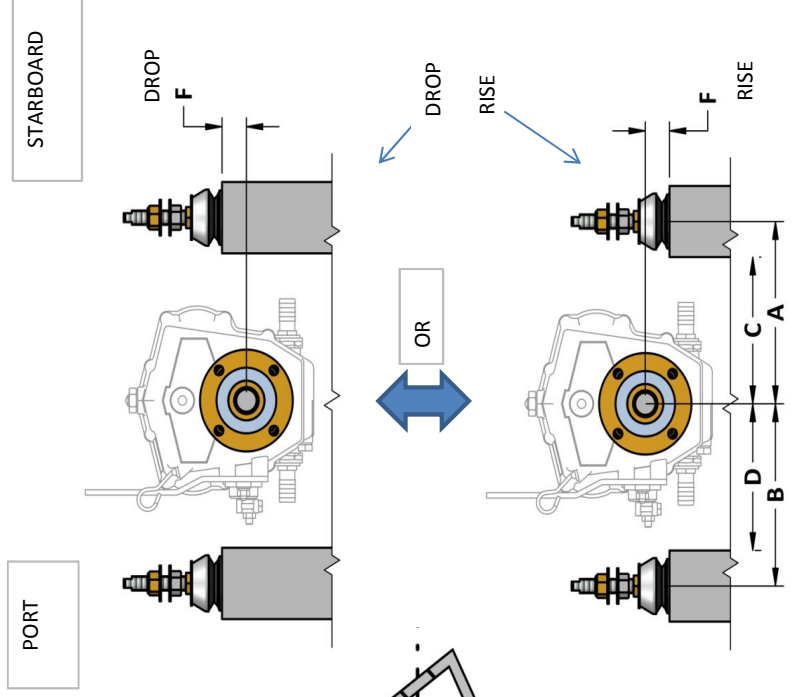

WOC NUMBER (IF KNOWN)	
NAME	
ADDRESS	
TEL	
E-MAIL	
ENGINE TYPE	
GEARBOX	

A	SHAFT CENTRE TO STARBOARD	H	SHAFT FACE TO CENTRE OF REAR MOUNT PORT
B	SHAFT CENTRE TO PORT	I	REAR MOUNT TO FRONT MOUNT PORT
C	SHAFT CENTRE TO INSIDE BEARER STARBOARD	H2	SHAFT FACE TO CENTRE OF REAR MOUNT STARBOARD
D	SHAFT CENTRE TO INSIDE BEARER PORT	I2	REAR MOUNT TO FRONT MOUNT STARBOARD
E	BEARER TOP TO HULL BOTTOM	J	ANGLE OF ENGINE
F	SHAFT CENTRE TO BEARER TOP	SHAFT FACE TO START OF BEARERS	
		BOAT TYPE:	
G	MAXIMUM BEARER LENGTH	OLD ENGINE TYPE:	