

**SDB**

**VARIABLE PITCH PROPELLERS**  
Use and maintenance handbook

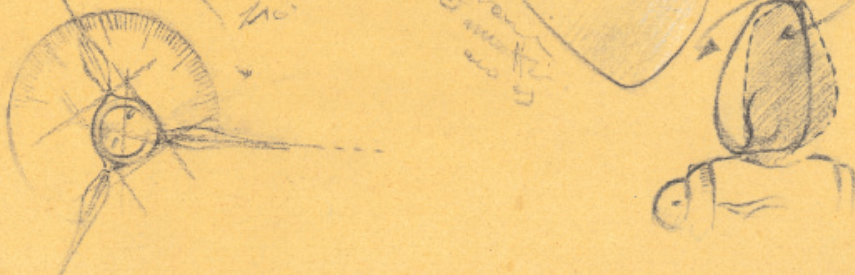



## **J PROP**

### **Variable pitch propeller**

Thank you for choosing a **JPROP** as the feathering propeller for your boat. This manual will provide you with the technical information needed to install, adjust and maintain your **JPROP**.

- **JPROP**'s patents, combined with the experience and machining skills of COBER, a fully integrated CNC specialist, are your assurance that **JPROP**'s performance meets your expectations.
- Sailors around the world wanted a safe, simple and efficient feathering prop, **JPROP** was designed to meet that challenge.
- **JPROP** is installed as simply as installing a fixed prop, an integral locknut ensures against losing your **JPROP**.
- Losing of **JPROP** is simple and fast, no disassembly needed.
- **JPROP**'s pitch can be adjusted by simply changing the setting of the ogival nose.

We appreciate your choice of **JPROP** and thank you for providing us with the information needed for proper prop selection.



# INDEX

Sect. 1 - PROPELLER INSTALLATION ON SAILDRIVE® SPLINE	page 2
Sect. 2 - PROPELLER REMOVAL FROM SAILDRIVE® SPLINE	page 9
Sect. 3 - PITCH ADJUSTMENT	page 13
Sect. 4 - REGULAR MAINTENANCE	page 18
Sect. 5 - SPARE PARTS LIST	page 22
Sect. 6 - NON-ROUTINE MAINTENANCE	page 27
- NOTES	page 30
TABLE 1 - Allen Keys needed for installation and removal	page 12
TABLE 2 - Pitch relative to selected notch/diameter	page 15

## Warning

**During propeller assembly and maintenance operations follow the rules of safety carefully, and in particular:**

- 1 - make sure that the engine is OFF and that it cannot be started accidentally,**
- 2 - when handling the propeller do not put your hands on the hub on the points where the blades rotate.**

## Section 1 - PROPELLER INSTALLATION ON A SAILDRIVE® SPLINE

To install your JPROP on an SD spline please follow these steps:

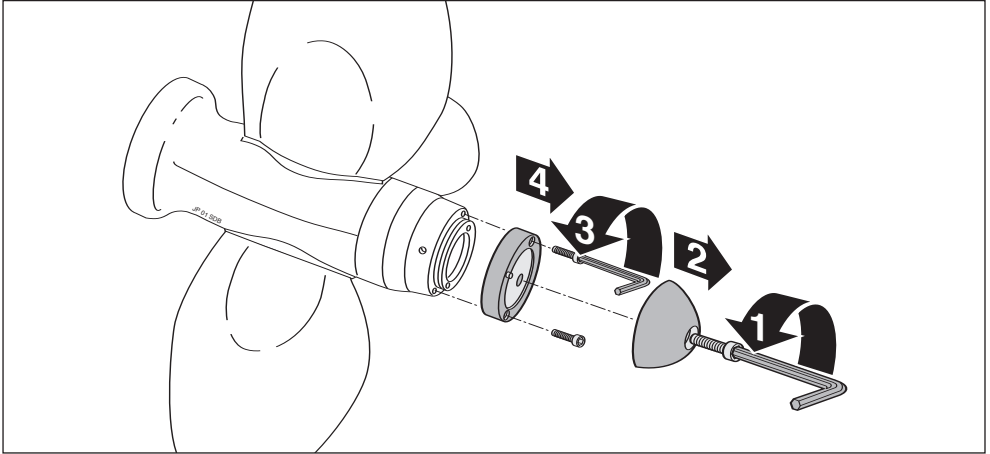

1 - remove zinc anode using Allen key type B ; remove bronze ring (anode support) using Allen key type C (see table 1 - section 2).

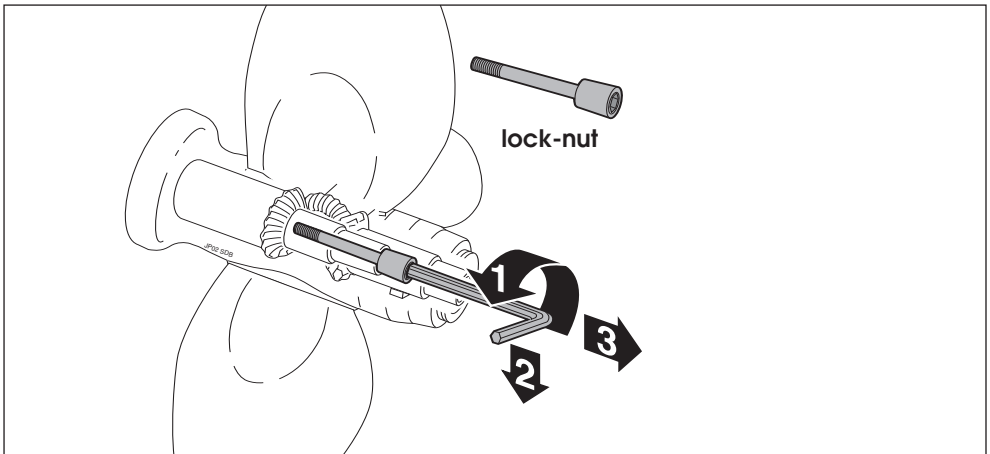

2 - Insert Allen key D into internal lock-nut and turn anti-clockwise until completely free, retract Allen key thus removing lock-nut.

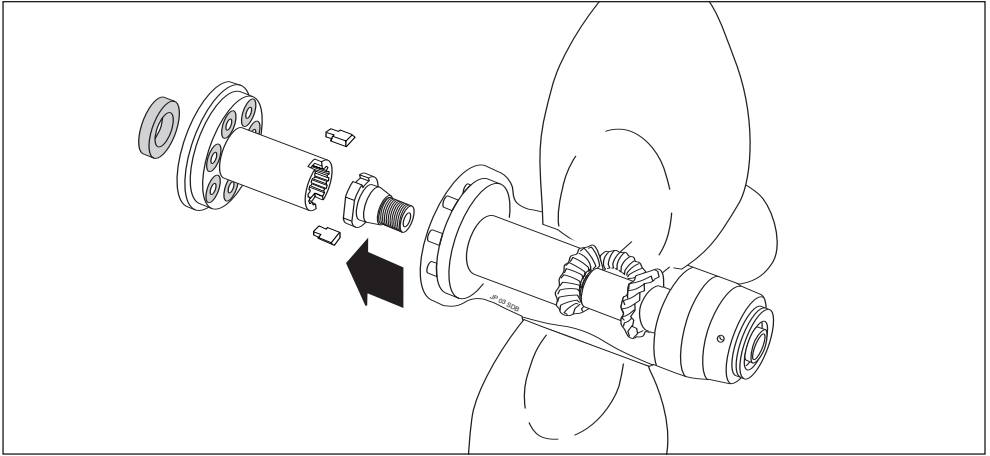

3 - remove the indicated parts: spacer, shock absorber, small keys and morse cone from their protection.

### Spacers 10.10

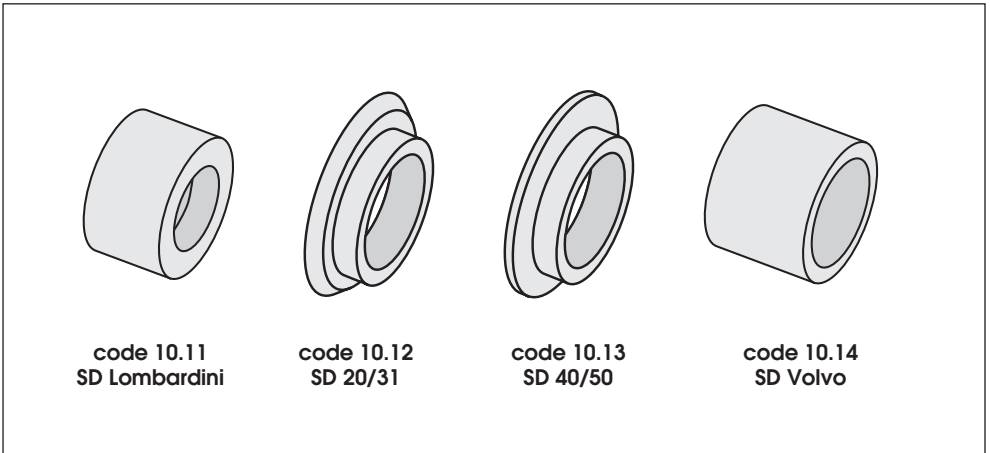

4 - check that the spacer corresponds to the type of shaft fitted to the Sail Drive leg.

**NB :** a Sonic leg does not require a spacer.

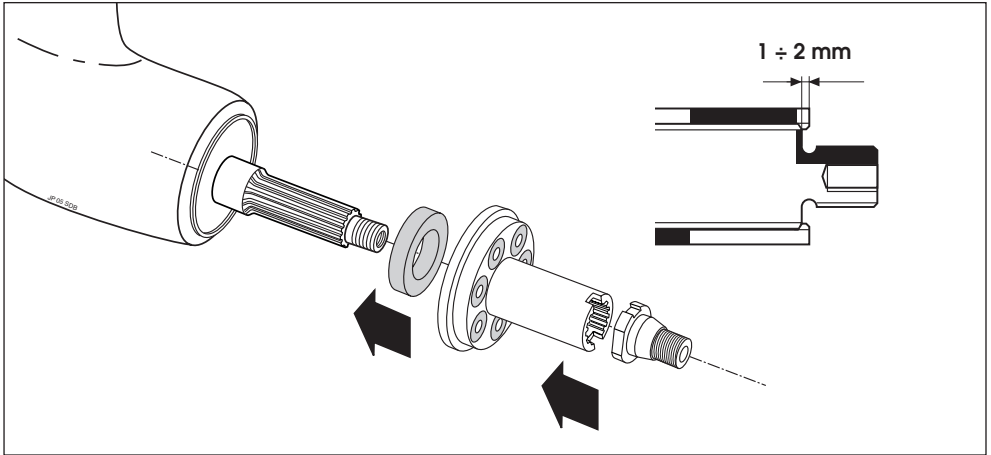

- 5 - fit the spacer, the shock absorber and the morse cone on to the propeller shaft.  
Check that the shock absorber sticks out by 1-2 mm from the surface of the propeller shaft.

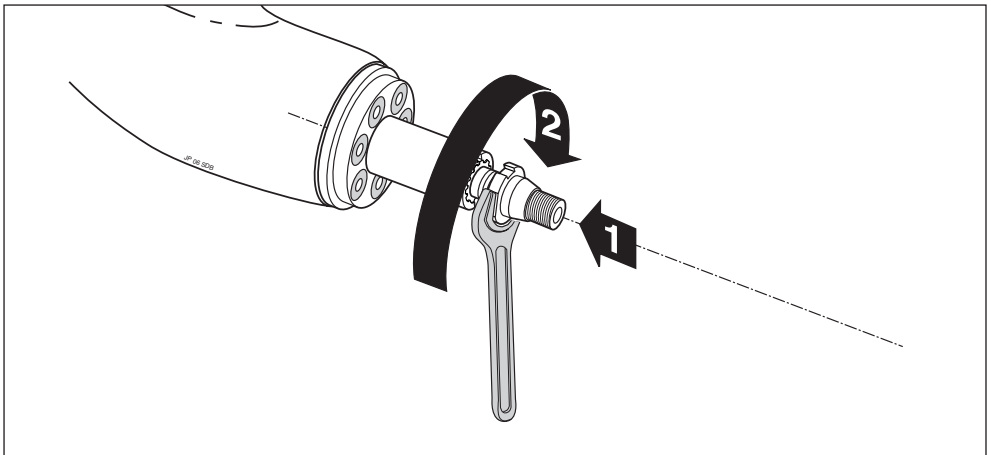

- 6 - apply thread-locking adhesive (Locktite) to the thread of the prop shaft.  
With a spanner (30 mm) screw the morse cone tightly right to the end of the shaft thread.

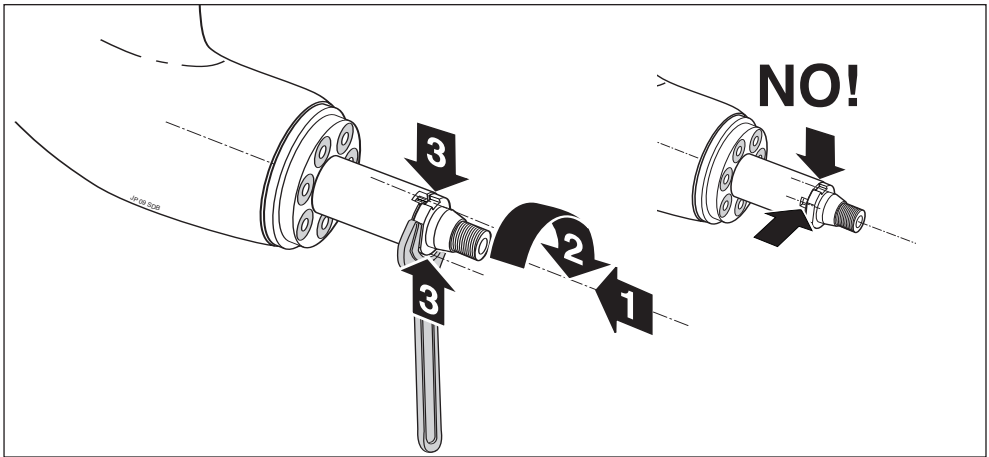

7 - check that the spaces for the little keys on the shock absorber and the Morse cone are aligned to allow for full locking.  
 If they are aligned, go to fig 10. If they are not aligned, go to fig 8.

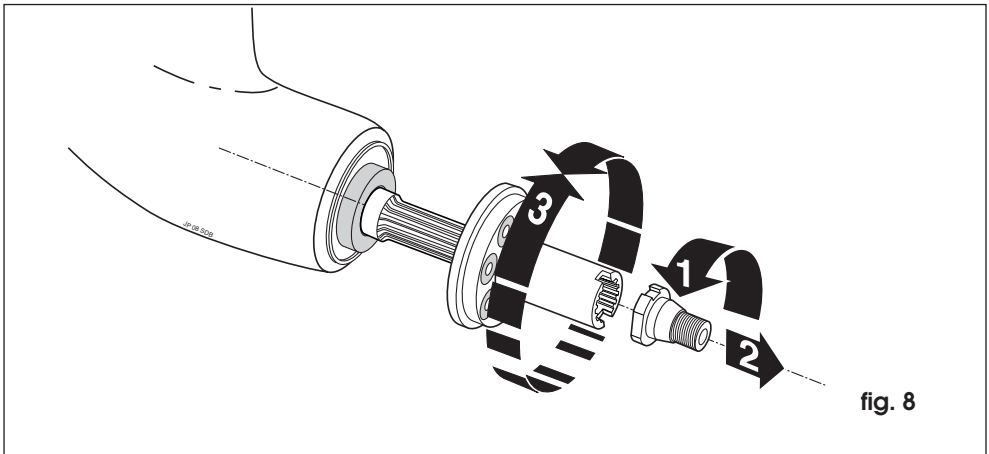

8 - unscrew the cone, remove the shock absorber and turn it, moving it by the number of grooves and in the direction required to align the spaces for the little keys.

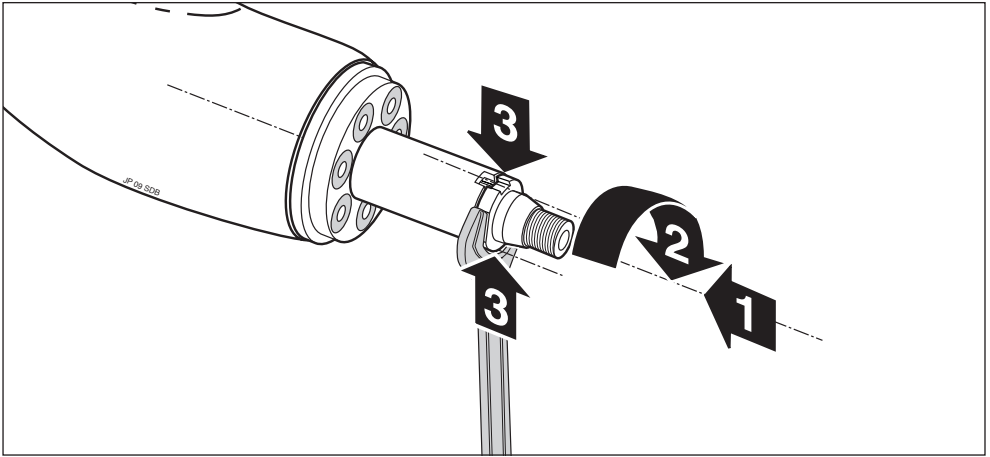

9 - apply thread-locking adhesive (Loctite) to the thread, and tighten with the 30 mm spanner until the spaces are aligned, as shown in the figure.

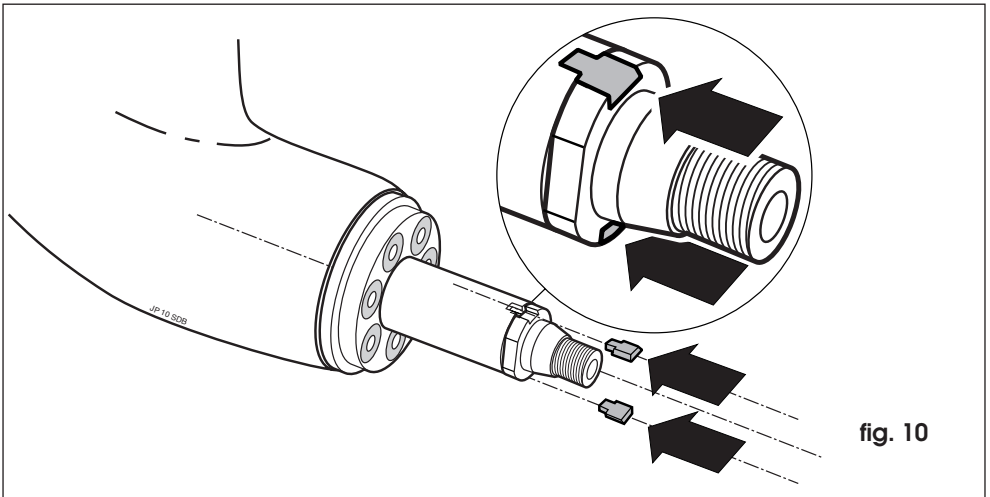
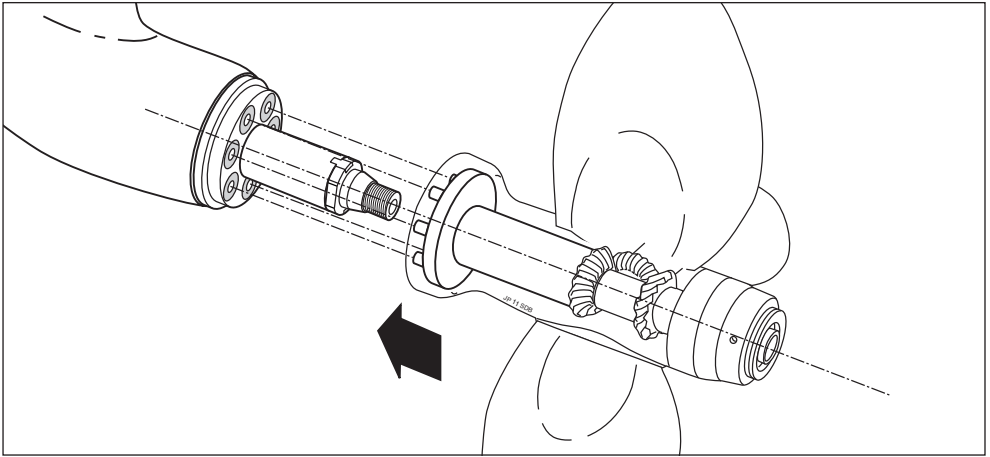

fig. 10

10 - fit the little keys into their seats, checking that they are fully inserted.





11 - fit the propeller body, making sure that you position and insert the pins into the rubber shock absorbers.

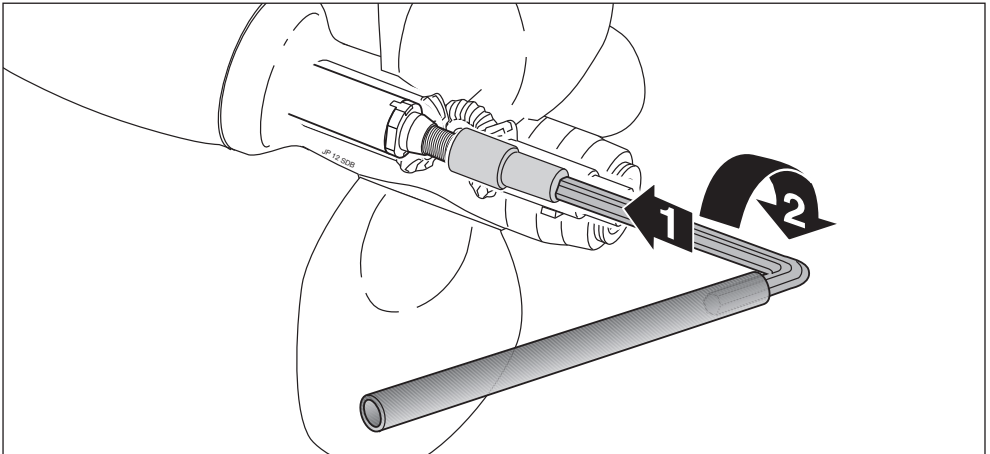

12 - using Allen key A tighten internal propshaft-nut applying a torque-load of 70 ft/lbs or 10 kgm.

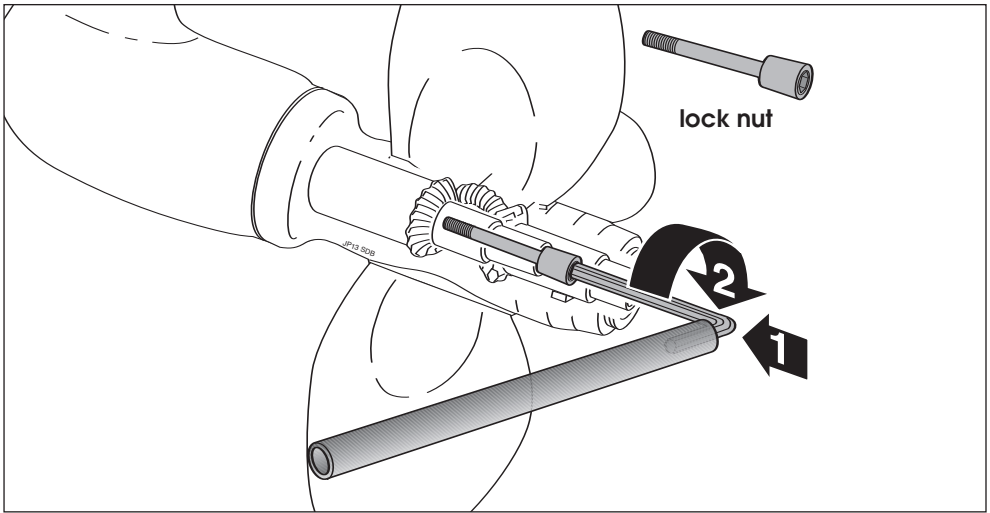

13 - apply threadlocking adhesive (LOCKTITE) to the threads. Insert and firmly tighten the lock-nut (Allen key type D with an extension of 12" or 30 cm).

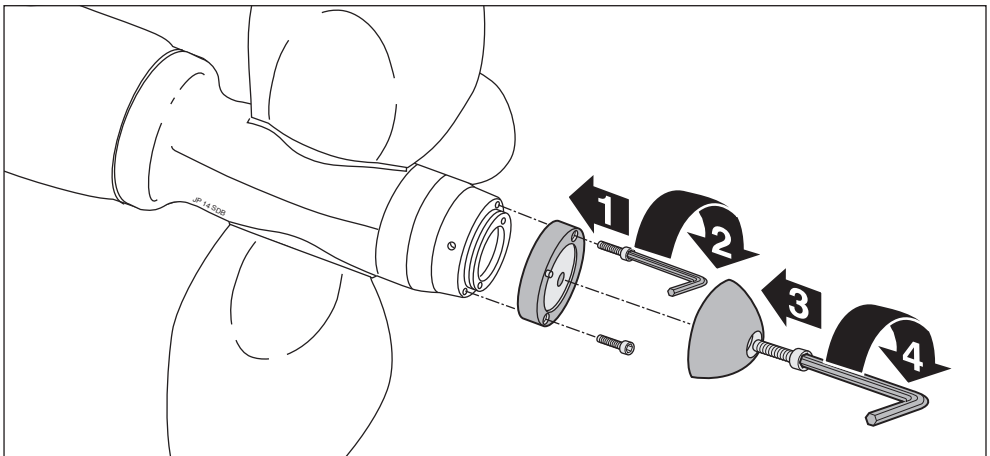

14 - followings instructions from section 3 (2 - 9) set the pitch for your JPROP.

15 - reinstall bronze ring (operat. 2, Allen key type C) and install anode. (operat. 4, Allen key type B)

**Installation of the anode is the last phase of this assembly operation. The zinc-anode has to protect your JPROP from cathodic corrosion, changing it when partly sacrificed will keep your JPROP in the best possible condition.**

## Section 2 - PROPELLER REMOVAL FROM SAILDRIVE® SPLINE.

To remove your JPROP from SD spline please follow these steps:

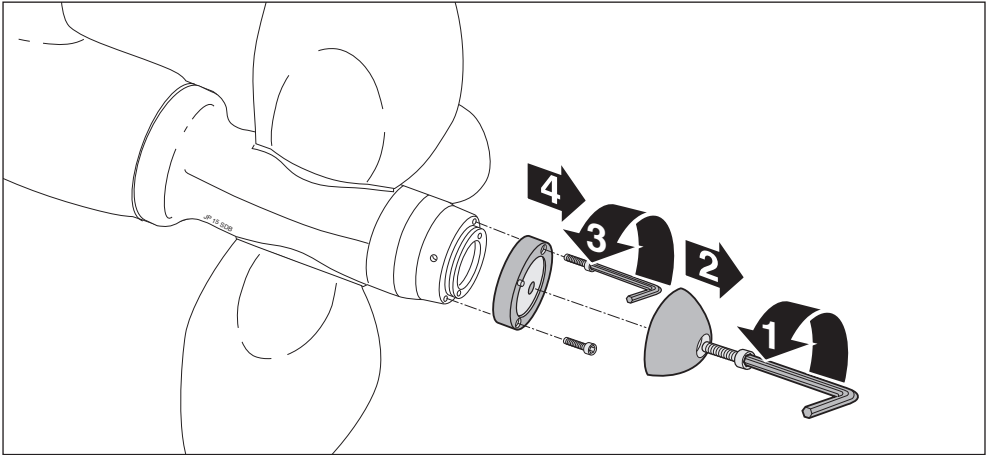

1 - remove zinc-anode using Allen key type B , remove bronze ring (anode support) using Allen key type C (see table 1 - section 2).

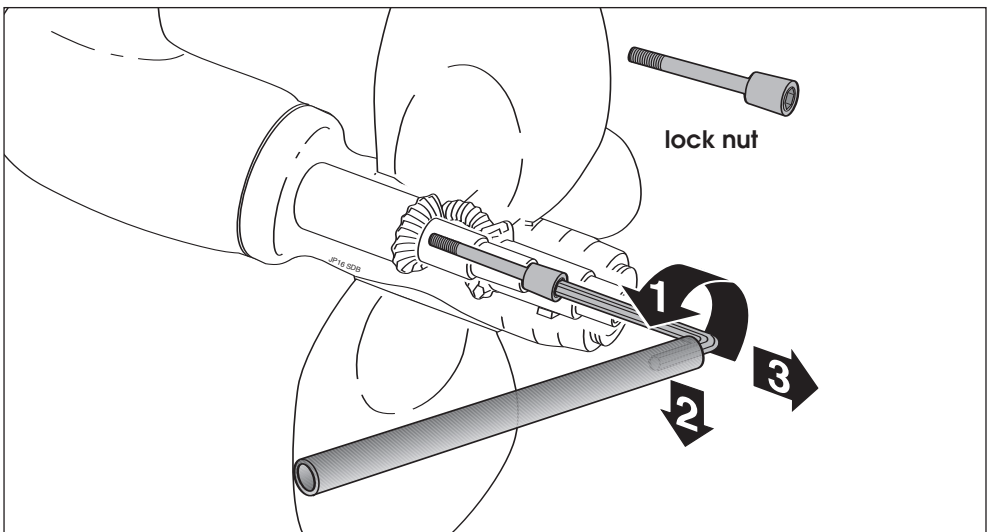

2 - insert Allen key type D into internal lock-nut and turn anti-clockwise until completely free. Retract Allen key thus removing lock-nut.

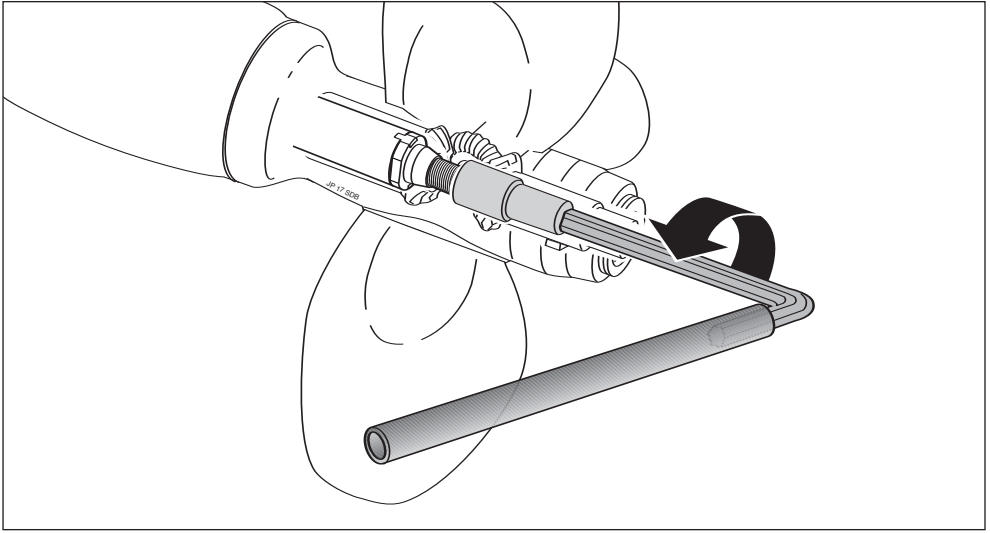

4 - using Allen key A loosen internal propshaft-nut (turn it anti- clockwise), this will probably require a torque-load of aprox. 80 ft/lbs or 12/15 kgm.

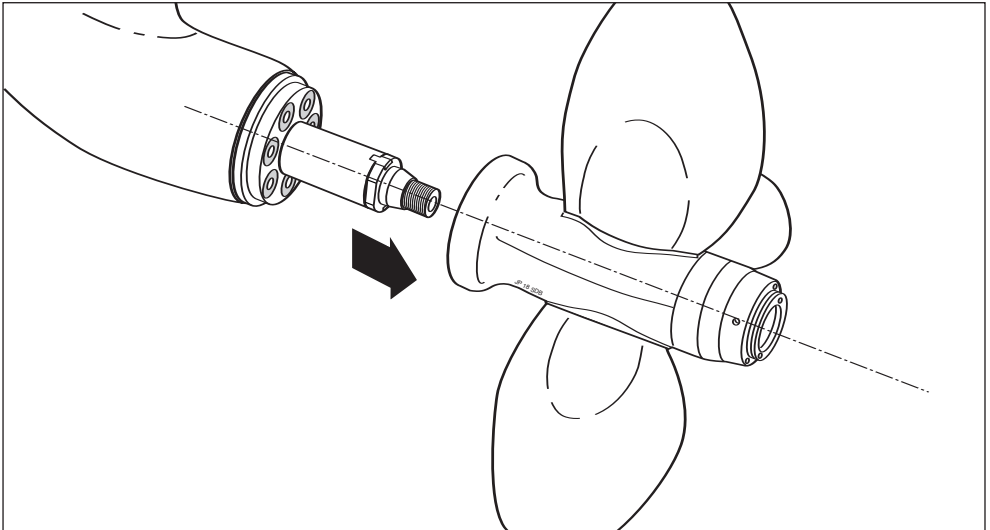

5 - when nut idles remove prop from spline.

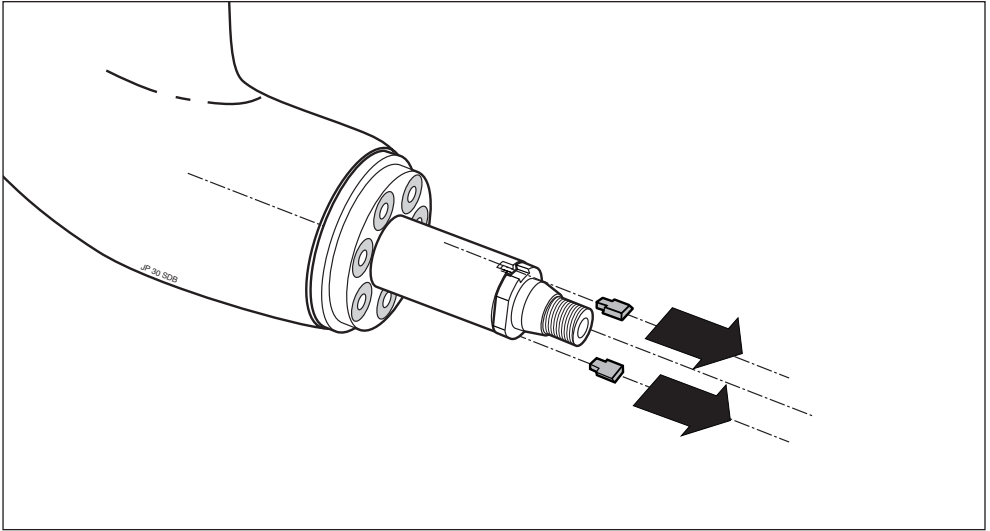

6 - remove the little keys from their seats.

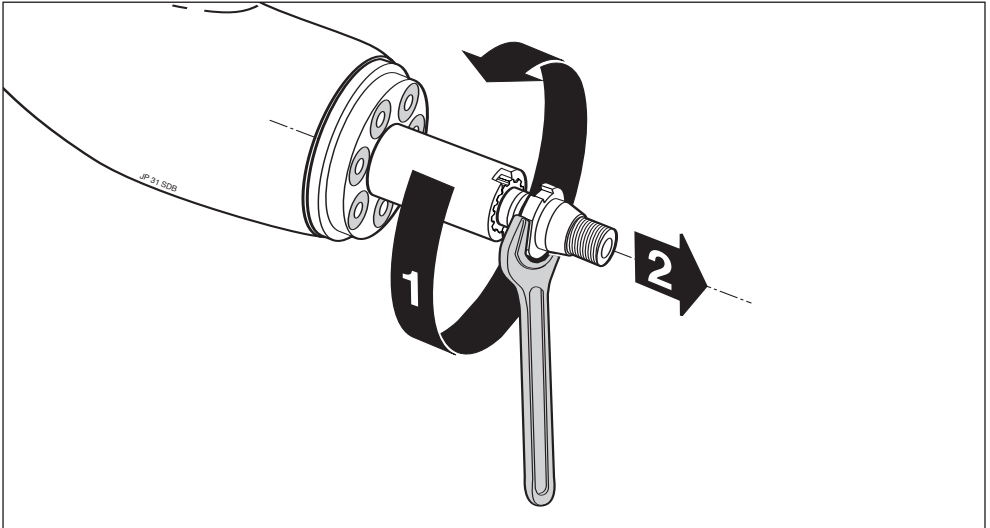

7 - with a 30 mm spanner unscrew the morse cone from the thread of the shaft.

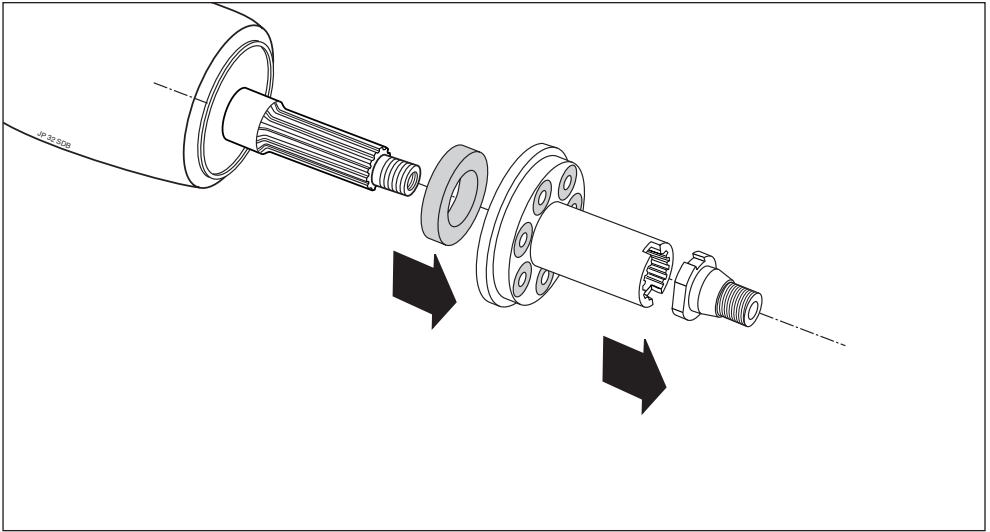

8 - remove the Morse cone, the shock absorber and the spacer from the prop shaft.

**TABLE 1**

**Allen keys to be used for installation and removal of JPROP**

prop type	Allen key A	Allen key B	Allen key C	Allen key D
body dia	mm	mm	mm	mm
63 SDB	14	6	3	8
83 SDB	14	6	3	8

### Section 3 - PITCH ADJUSTMENT

It's possible to adjust the pitch anytime following these procedures:

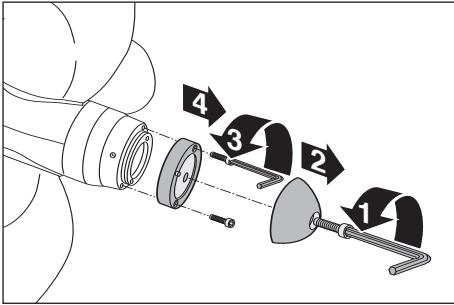

1 - remove the zinc anode and the bronze ring (anode support) with the Allen keys B and C (see page 6).

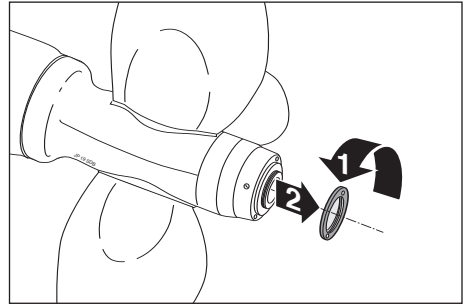

2 - remove the bronze «pitch-lock» flange

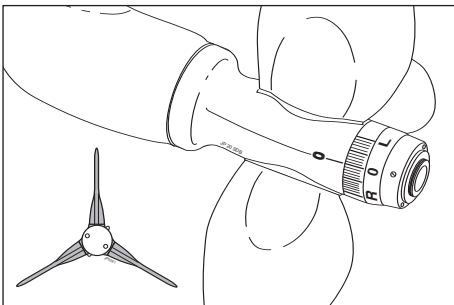

3 - put the propeller's blade in feathering position.

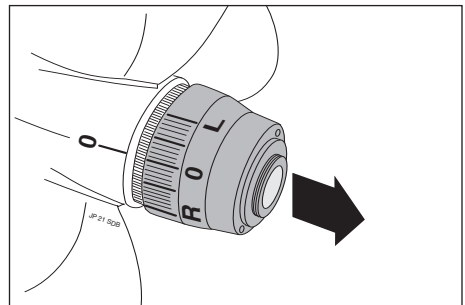

4 - pull the ogival nose.

**Warning :** when the boat is out of the water the movement of the ogival nose is easy. When the boat is in the water it takes more time to pull the ogival nose as water has to fill the void created by the action. Drains are built into the ogival nose to allow flooding of the void.

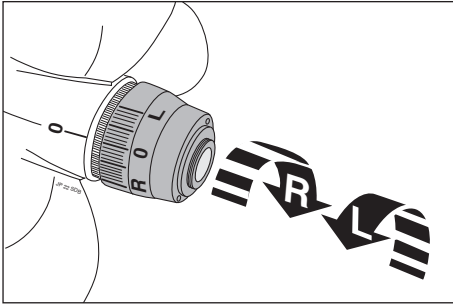

5 - Turn the ogival nose towards the «R» or «L» side depending on the type of engine (rightway or leftway) and reach the notch of the desired pitch.

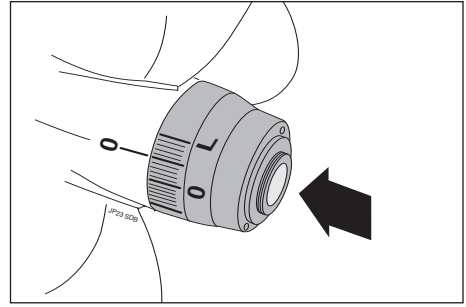

6 - release the ogival nose  
 7 - make sure that the reference line «0» matches the desire notch.  
 8 - make sure that the ogival nose backs itself firmly against the props body.

**Warning:** if you are sure that you reached the right pitch, reinstall the bronze «pitch-lock» flange in order to lock the ogival nose, but if you plan to modify it again while the boat is in the water, do not install it now.

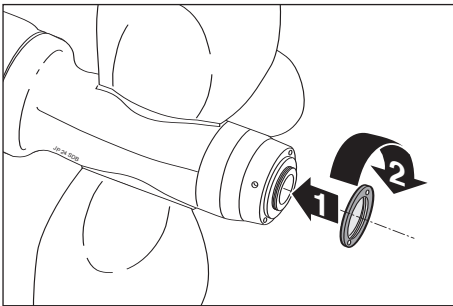

9 - reinstall the bronze «pitch-lock» flange

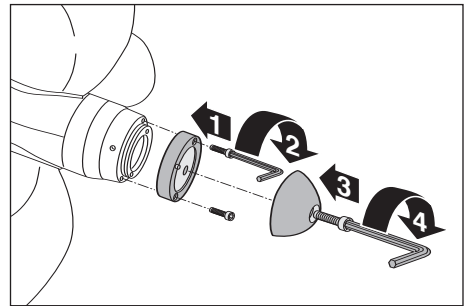

10 - put on the bronze ring and the zinc anode.

**Warning:** failure to fit the bronze ring in actual use could cause the propeller's pitch to vary, due to external factors, with consequent damage to mechanical parts



### Propeller pitch

The table gives the real value of the increment of the blades' angle of attachment expressed in degrees per notch and according to the type of propeller.

<b>Propeller body Ø</b>	<b>63</b>	<b>83</b>
<b>Increase ( ° )</b>	2,613	2,348

### Calculation of the slip:

The following tables give the theoretical value of the pitch.

To obtain the real value multiply the datum being examined by a reduction factor of 0.55.

*E.g.: propeller body 83, Ø 19", adjusted to the 10th step.*

*Theoretical pitch \*24,655 "/rot. Real pitch: 24,655 x 0,55 = 13,560 "/rot.*

### PROPELLER HUB Ø 63 Pitch in inches per rotation

Propeller diameter

Notch	Propeller diameter					
	13"	14"	15"	16"	17"	18"
1	1,863	2,007	2,150	2,293	2,437	2,580
2	3,735	4,022	4,309	4,597	4,884	5,171
3	5,622	6,054	6,487	6,919	7,352	7,784
4	7,533	8,112	8,692	9,271	9,851	10,430
5	9,476	10,205	10,934	11,663	12,392	13,121
6	11,462	12,343	13,225	14,107	14,988	15,870
7	13,498	14,537	15,575	16,613	17,652	18,690
8	15,597	16,797	17,997	19,197	20,397	21,596
9	17,771	19,138	20,505	21,872	23,239	24,606
10	20,032	21,573	23,114	*24,655	26,196	27,737
11	22,397	24,120	25,843	27,566	29,289	31,012
12	24,884	26,798	28,712	30,626	32,541	34,455
13	27,512	29,626	31,745	33,862	35,978	38,095
14	30,308	32,640	34,971	37,302	39,634	41,965
15	33,300	35,861	38,423	40,984	43,546	46,107
16	36,522	39,332	42,141	44,951	47,760	50,570

### Calculation of the slip:

The following tables give the theoretical value of the pitch.

To obtain the real value multiply the datum being examined by a reduction factor of 0.55.

E.g.: propeller body 83, Ø 19", adjusted to the 10th step.

Theoretical pitch \*25.926 "/rot. Real pitch: 25.926 x 0.55 = 14.259 "/rot.

### PROPELLER HUB Ø 83 Pitch in inches per rotation

Propeller diameter

Notch	16"	17"	18"	19"	20"	21"	22"
1	2,060	2,189	2,318	2,447	2,576	2,704	2,833
2	4,128	4,386	4,644	4,902	5,160	5,418	5,676
3	6,210	6,598	6,986	7,374	7,762	8,151	8,539
4	8,313	8,832	9,352	9,872	10,391	10,911	11,430
5	10,444	11,097	12,403	11,663	13,056	13,709	14,361
6	12,613	13,401	14,198	14,978	15,766	16,554	17,343
7	14,826	15,753	16,679	17,606	18,533	19,459	20,386
8	17,094	18,162	19,231	20,299	21,376	22,436	23,504
9	19,425	20,640	21,854	23,068	24,282	25,496	26,710
10	21,832	23,197	24,561	25,926	27,290	28,655	30,019
11	24,326	25,847	27,367	28,888	30,408	31,928	33,449
12	26,921	28,604	30,287	31,969	33,652	35,334	37,017
13	29,633	31,485	33,337	35,189	37,041	38,893	40,745
14	32,479	34,509	36,539	38,569	40,599	42,629	44,659
15	35,480	37,697	39,915	42,132	44,350	46,567	48,785
16	38,659	41,076	43,942	45,908	48,324	50,741	53,157



## Section 4 - REGULAR MAINTENANCE

The **JPROP** propeller needs very little maintenance. Periodic maintenance, as described below, however will help you achieve best performance, both in efficiency as well as durability.

### Regular maintenance.

**Periodically replace the zinc-anode in order to avoid damage due to cathodic corrosion.**

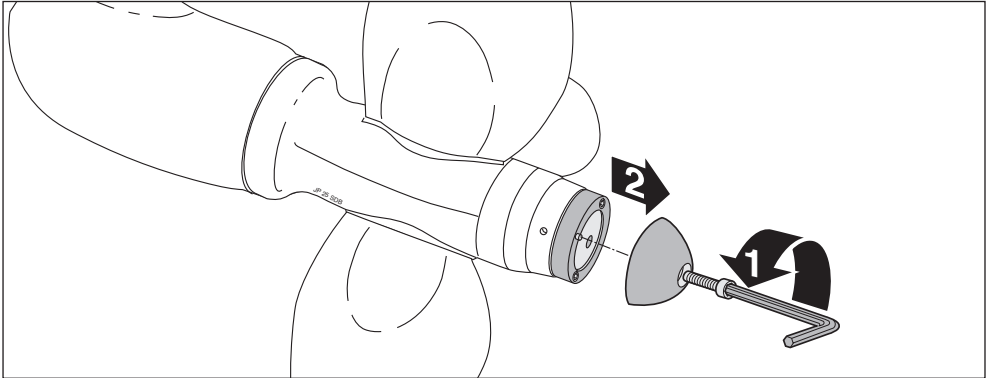

1 - remove the old anode (Allen key type B - table 1)

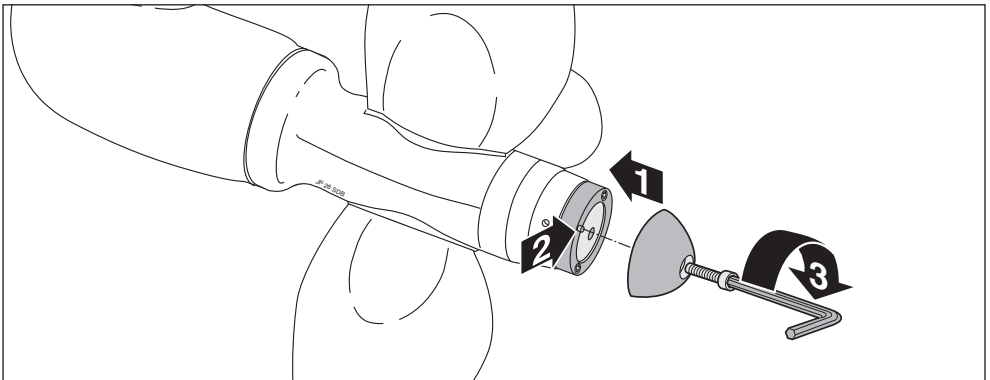

2 - install the new anode taking care that the projection on the anode fits the cavity in the bronze ring.

## Lubrication.

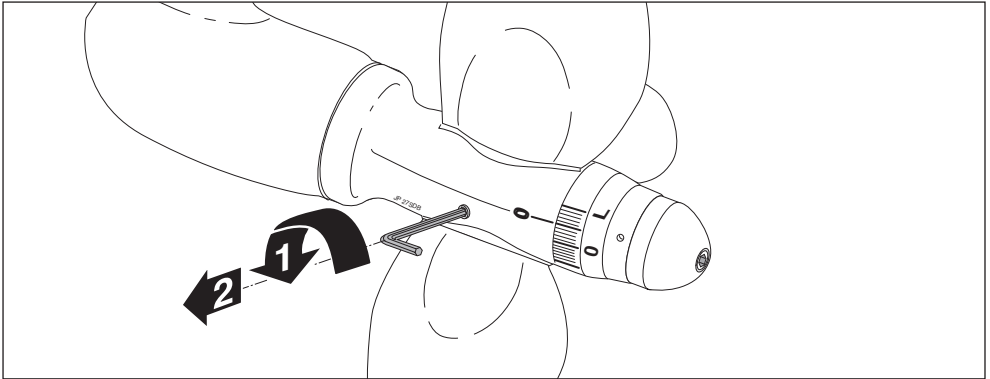

1 - unscrew the Allen screw under the red dot (Allen key D - table 1).

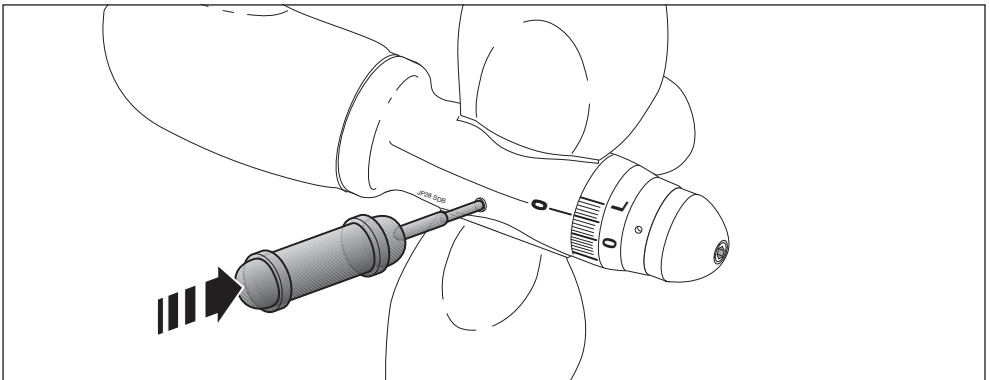

- 2 - Fill the propeller hub with marine grease using the grease-gun  
(grease suggested: TECNOLUBE Polimar 400 or SHELL Nautilus SRS 2000),  
3 - replace the Allen screw in the propeller and seal with a silicon sealer.

**Non-routine maintenance** (see section 6 page 7)

**For any other problem contact the nearest agent or the manufacturer.**

**The manufacturer assumes no responsibility for any damages due to incorrect installation, use or maintenance of the product.**

## SUMMARY OF ROUTINE MAINTENANCE

- GREASE the propeller at least once a year

- REPLACE the zinc anode at least once a year

- DO NOT PAINT, and keep clean, the contact surfaces between propeller, zinc anode support and zinc anode.

- DO NOT PAINT the contact surfaces between the body and the blades with antifouling paint or anything else.

By carrying out these simple operations regularly, and observing the warnings, you will get the maximum performance from your *JPROP* propeller.



## Section 5 - SPARE PARTS LIST

### Propeller hub $\varnothing$ 63 - SDB

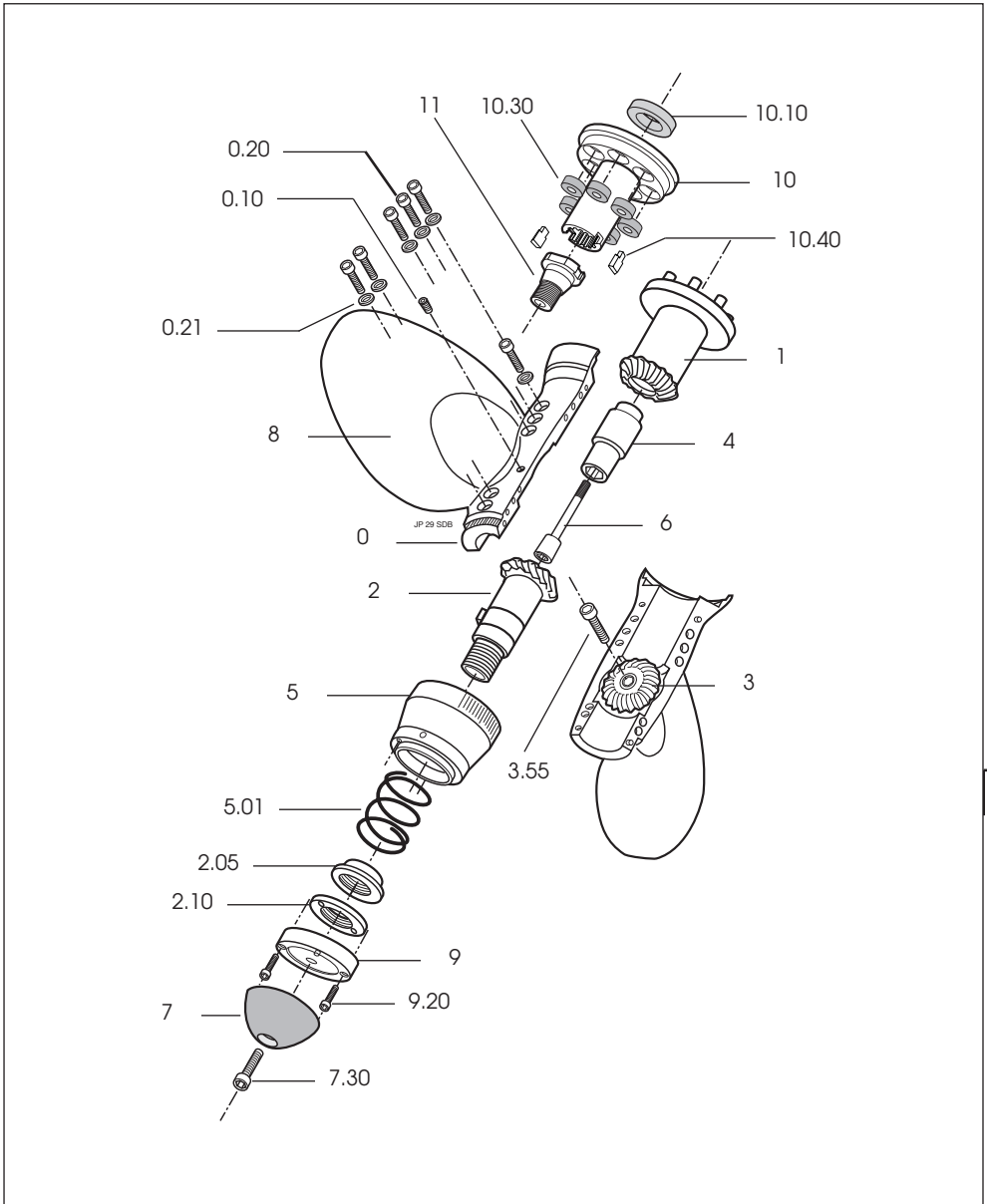



## Spare parts list for propeller hub Ø 63 - SDB

Ref.	Description	Codex JP
0	Hub sector	63.00.30
0,10	Allen screw UNI 5927 M6x8 pc A4	63.00.10
0.20	Allen screw TCE UNI 5931 M6x20 A4	63.00.20
0.21	Washer DIN 7980 M6 A4	63.00.21
1	Conical junction	63.01.00
2	Lock	63.02.00
2.05	Spring-lock flange	63.02.06
2.10	"Pitch-lock" flange	63.02.10
3	Satellite	63.03.00
3.55	Allen screw TCE UNI 5931 M8x55 A4	63.03.56
4	Retaining nut	63.04.00
5	Ogival nose	63.05.00
5.01	Recall spring	63.05.01
6	Lock nut	63.06.00
7	Zinc anode	63.07.00
7.30	Vite TCE UNI 5931 M8x30 A4	63.07.30
8	Blade	63.08.00
9	Bronze ring	63.09.00
9.20	Allen screw TCE UNI 5931 M4x20 A4	63.09.20
10	Shock absorber	63.10.00
10.10	Spacer (The Sonic SD leg does not require spacers)	63.10.10
10.30	Bushes	63.10.30
10.40	Small keys	63.10.40
11	Nut with morse cone	63.11.00

# Propeller hub Ø 83 - SDB

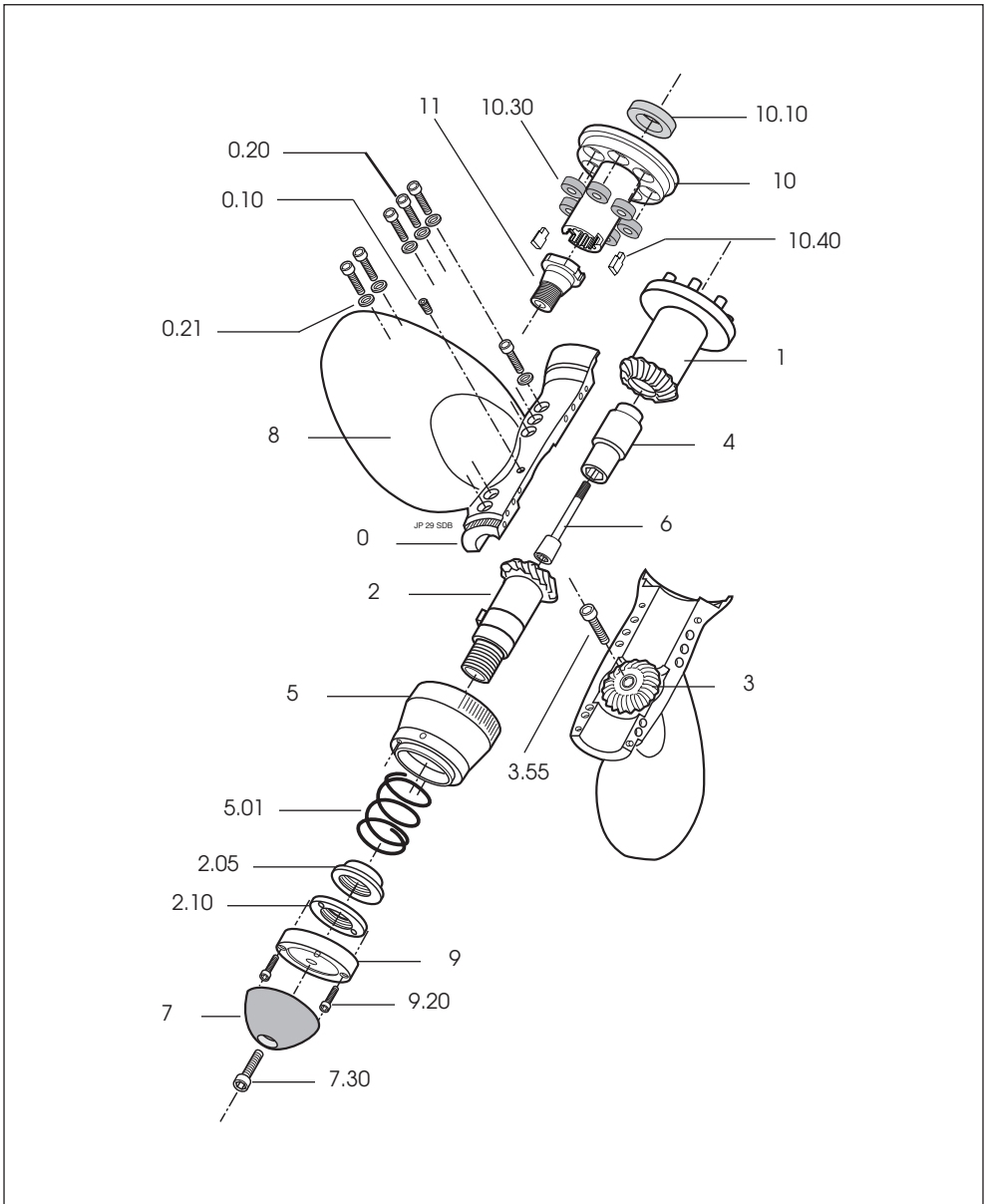

## Spare parts list for propeller hub Ø 83 - SDB

Ref.	Description	Codex JP
0	Hub sector	83.00.30
0,10	Allen screw UNI 5927 M6x8 pc A4	83.00.10
0.20	Allen screw TCE UNI 5931 M6x20 A4	83.00.20
0.21	Washer DIN 7980 M6 A4	83.00.21
1	Conical junction	83.01.00
2	Lock	83.02.00
2.05	Spring-lock flange	83.02.06
2.10	"Pitch-lock" flange	83.02.10
3	Satellite	83.03.00
3.55	Allen screw TCE UNI 5931 M8x55 A4	83.03.56
4	Retaining nut	83.04.00
5	Ogival nose	83.05.00
5.01	Recall spring	83.05.01
6	Lock nut	83.06.00
7	Zinc anode	83.07.00
7.30	Vite TCE UNI 5931 M8x30 A4	83.07.30
8	Blade	83.08.00
9	Bronze ring	83.09.00
9.20	Allen screw TCE UNI 5931 M4x20 A4	83.09.20
10	Shock absorber	83.10.00
10.10	Spacer (The Sonic SD leg does not require spacers)	83.10.10
10.30	Bushes	83.10.30
10.40	Small keys	83.10.40
11	Nut with morse cone	83.11.00



## Section 5/a - SPARE PARTS - ENGINE TYPE REFERENCE

### Nut with morse cone ref 11 – type of thread

Ref	Type of leg	Thread	JP Code
11.11	Volvo SD 110-120-130	M 16 x 2	83.11.11
11.11	Yanmar SD 20/31	M 16 x 2	83.11.11
11.12	Yanmar SD 40/50	M 20 x 2	83.11.12
11.11	Lombardini SD	M 16 x 2	83.11.11
11.13	SONIC	5/8 UN 11 filetti	83.11.13

### Spacers Ref. 10.10

Ref	Type of leg	Thread	JP Code
10.11	Lombardini SD	83.10.11	
10.12	Yanmar SD 20/31	83.10.12	
10.13	Yanmar SD 40/50	83.10.13	
10.14	Volvo SD	83.10.14	

**Note:** the Sonic SD leg does not require spacers

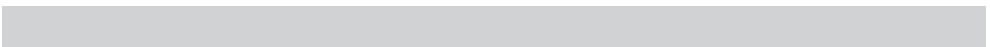
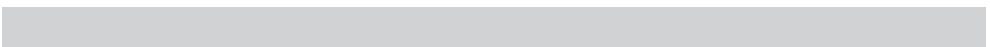

## Section 6 – NON-ROUTINE MAINTENANCE

### ATTENTION!

**Non-routine maintenance must be undertaken in the factory or an authorized workshop.**

Any non-routine maintenance operation (opening up the propeller), carried out by unauthorized persons will **IMMEDIATELY TERMINATE THE GUARANTEE.**

In case of malfunction which requires the opening of the propeller, and if it is impossible for technical reasons or time constraints, to send it to the factory, **ANY INTERVENTION BY 3<sup>rd</sup> PARTIES MUST BE APPROVED AND AUTHORIZED BY MARINE PROPELLER SRL IN WRITING.**

Thus we consider ourselves relieved of any responsibility for damage caused to the propeller by non-routine interventions carried out by the customer or unauthorized third parties.

### Notes on fitting the propeller

1- align the semi-circular locking device on the pinion with the locking surface on the propeller body section.

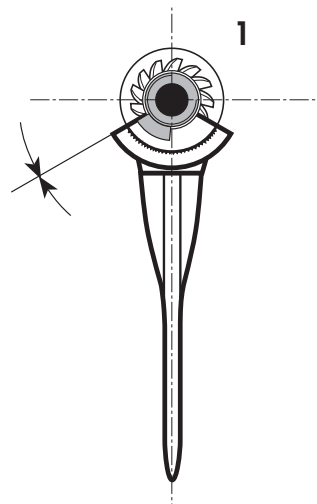

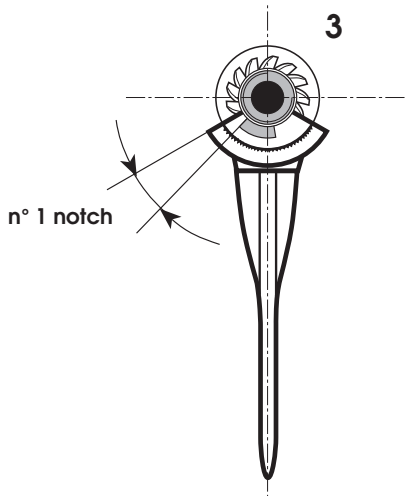
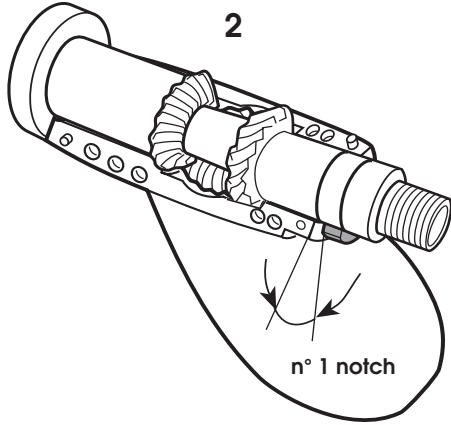

2 - 3 - moving the pinion by one notch, turn the hub anti-clockwise.

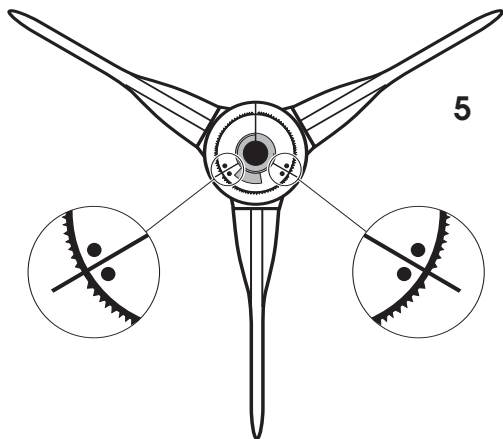
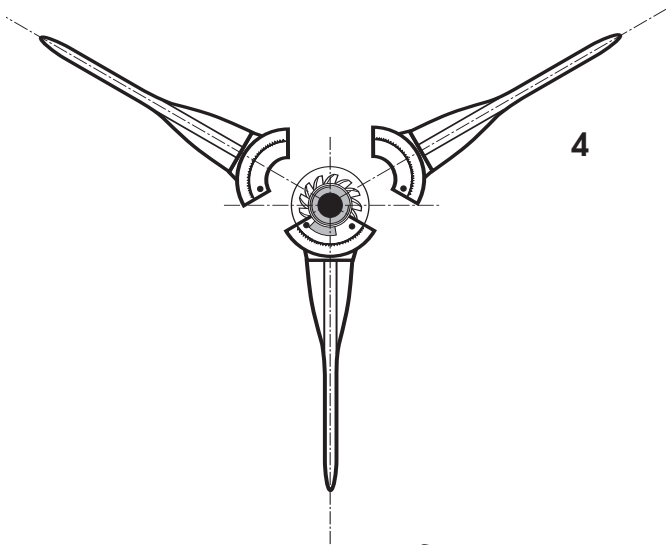

4 - 5 - close the propeller aligning the three sections with the punched holes as illustrated in figure 5

**ATTENTION!** - Non-routine maintenance must be carried out by the manufacturer or by authorized workshops.

**NOTE:**

Please take note on these pages of the pitch adjustments made as well as dates of last servicing, lubrication, anode inspection.

Blank lined area for notes, consisting of 18 horizontal grey bars.





**NOTE:**

[Redacted content]





**MARINE PROPELLER** s.r.l.

**Distribution Network:**

USA

**BETA MARINE U.S. Ltd.**

PO Box 5 - 11702 Hwy 306S - Minnesott Beach, NC 28510

**Tel:** (252) 249-2473 - **Fax:** (252) 249-0049

**Toll Free:** (877) 227-2473

England :

**Calibra Marine International Ltd.**

Deacons Boatyard - Bursledon Bridge - Southampton

Hampshire - SO31 8AZ - UNITED KINGDOM

**Tel.** 0044 08702400358 - **Fax :** 0044 08702400359

[www.calibramarine.co.uk](http://www.calibramarine.co.uk)

e-mail: [sales@calibramarine.com](mailto:sales@calibramarine.com)

France:

**PRONAUTIQUE**

3 Avenue Jean Graille - 13600 La ciotat - FRANCE

**Tel.** 0033.06.84544105 - **Fax.** 0033.4.42728636

[www.pronautique.fr](http://www.pronautique.fr) e-mail: [jmarnaud@pronautique.fr](mailto:jmarnaud@pronautique.fr)

Germany:

**GROVER PROPELLER GmbH**

Von-Hunefeld-Straße 101 - 50829 Koln

(Gewerbegebiet Ossendorf) - Deutschland

**Tel. :** +49 2 21593042 - **Fax :** +49 2 21594298

[www.groever-propeller.de](http://www.groever-propeller.de)

e-mail: [groever@netcologne.de](mailto:groever@netcologne.de)

Italy: **MARINE PROPELLER s.r.l.**

- Via Olona, 9 - 21054 Fagnano Olona (VA) - Italy - tel +39 0331 614085 (r.a.) - fax +39 0331 612668
- [www.marinepropeller.it](http://www.marinepropeller.it) - e-mail: [eleonora@prop.it](mailto:eleonora@prop.it)

Canada:

**STRIGHR-MACHAY LTD.**

P.O. Box 97 209 Terra Cotta Drive, New Glasgow,

Nova Scotia - Canada B2H 5E1

**Tel.** (902) 928-1900 - **Fax.** (902) 928-1905

[www.stright-mackay.com](http://www.stright-mackay.com)

e-mail: [info@stright-mackay.com](mailto:info@stright-mackay.com)

Holland :

**SIP MARINE**

Lipsstraat 50 - 5151 RP Drunen - The Netherlands

**Tel.:** +31 (0) 416 383 262 - **Fax :** +31 (0)6 30 22 30 42

[www.SipMarine.com](http://www.SipMarine.com)

e-mail: [sjouke.sipkema@SipMarine.com](mailto:sjouke.sipkema@SipMarine.com)

Finland:

**MEPRATUOTE OY**

Kaviokuja 8 - FIN 20380 Turku - Finland

**Tel. :** +358 2 2750111 - **Fax :** +358 2 2750120

[www.mepratuote.fi](http://www.mepratuote.fi) e-mail: [info@mepratuote.fi](mailto:info@mepratuote.fi)